

GT75FB60A1H

IGBT Module

Preliminary Date

Features:

- Short Circuit Rated $>5\mu\text{s}$
- Low Saturation Voltage: $V_{CE(sat)} = 1.90\text{V} @ I_C = 75\text{A}, T_C=25^\circ\text{C}$
- Low Switching Loss
- 100% RBSOA Tested ($2 \times I_C$)
- Low Stray Inductance
- Lead Free, Compliant with RoHS Requirement



Applications:

- Industrial Inverters
- Servo Applications
- UPS Systems

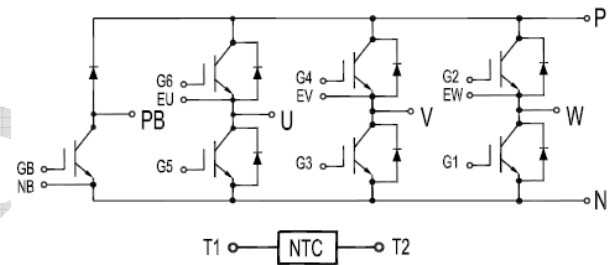

IGBT, Inverter

Maximum Rated Values ($T_C=25^\circ\text{C}$ unless otherwise specified)

V_{CES}	Collector-Emitter Blocking Voltage		600	V
V_{GES}	Gate-Emitter Voltage		± 20	V
I_C	Continuous Collector Current	$T_C = 100^\circ\text{C}$	75	A
		$T_C = 25^\circ\text{C}$	100	A
I_{CM}	Peak Collector Current Repetitive	$T_J = 175^\circ\text{C}$	150	A
t_{SC}	Short Circuit Withstand Time		>5	μs
P_D	Maximum Power Dissipation (IGBT)	$T_C = 25^\circ\text{C}$ $T_{Jmax} = 175^\circ\text{C}$	385	W

Electrical Characteristics of IGBT ($T_C=25^{\circ}\text{C}$ unless otherwise specified)

Static Characteristics

Symbol	Description	Conditions	Min	Typ	Max	Unit
$V_{GE(th)}$	Gate-Emitter Threshold Voltage	$I_C = 1 \text{ mA}, V_{CE} = V_{GE}$	5.0	5.5	6.5	V
$V_{CE(sat)}$	Collector-Emitter Saturation Voltage	$I_C = 75 \text{ A}, V_{GE} = 15 \text{ V}$	$T_J = 25^{\circ}\text{C}$	1.90	2.10	V
			$T_J = 125^{\circ}\text{C}$	2.10		V
I_{CES}	Collector-Emitter Leakage Current	$V_{GE} = 0 \text{ V}, V_{CE} = V_{CES}, T_J = 25^{\circ}\text{C}$			1	mA
I_{GES}	Gate-Emitter Leakage Current	$V_{GE} = \pm 20 \text{ V}, V_{CE} = 0 \text{ V}, T_J = 25^{\circ}\text{C}$			200	nA
C_{ies}	Input Capacitance	$V_{CE} = 25 \text{ V}, V_{GE} = 0 \text{ V}, f = 1 \text{ MHz}$		4.45		nF
C_{oes}	Output Capacitance			0.25		nF
C_{res}	Reverse Transfer Capacitance			0.13		nF

Switching Characteristics

$t_{d(on)}$	Turn-on Delay Time	$V_{CC} = 300 \text{ V}, I_C = 75 \text{ A}, R_G = 15 \Omega, V_{GE} = \pm 15 \text{ V},$ Inductive Load	$T_J = 25^{\circ}\text{C}$		150		ns
			$T_J = 125^{\circ}\text{C}$		147		
t_r	Rise Time		$T_J = 25^{\circ}\text{C}$		90		ns
			$T_J = 125^{\circ}\text{C}$		89		
$t_{d(off)}$	Turn-off Delay Time		$T_J = 25^{\circ}\text{C}$		110		ns
			$T_J = 125^{\circ}\text{C}$		113		
t_f	Fall Time		$T_J = 25^{\circ}\text{C}$		75		ns
			$T_J = 125^{\circ}\text{C}$		94		
E_{on}	Turn-on Switching Loss		$T_J = 25^{\circ}\text{C}$		1.15		mJ
			$T_J = 125^{\circ}\text{C}$		1.55		
E_{off}	Turn-off Switching Loss	$T_J = 25^{\circ}\text{C}$		0.50		mJ	
		$T_J = 125^{\circ}\text{C}$		0.90			
Q_g	Total Gate Charge	$T_J = 25^{\circ}\text{C}$		220		nC	
		$T_J = 125^{\circ}\text{C}$		226			
RBSOA	RBSOA	$I_C=150\text{A}, V_{CC}=480\text{V}, V_p=600\text{V}, R_g = 15\Omega, V_{GE}=+15\text{V to } 0\text{V}, T_J = 150^{\circ}\text{C}$	Trapezoid				
SCSOA	SCSOA	$V_{CC} = 300 \text{ V}, V_{GE} = 15 \text{ V}, T_J = 150^{\circ}\text{C}$	5			μs	
$R_{\theta JC}$	IGBT Thermal Resistance: Junction-To-Case (Per Leg)			0.388		$^{\circ}\text{C/W}$	

Diode, Inverter

Maximum Rated Values($T_C=25^\circ\text{C}$ unless otherwise specified)

V_{RRM}	Repetitive Peak Reverse Voltage	600	V
I_F	Diode Continuous Forward Current	75	A
I_{FM}	Peak FWD Current Repetitive	150	A

Electrical Characteristics of FWD($T_C=25^\circ\text{C}$ unless otherwise specified)

Symbol	Description	Conditions	Min	Typ	Max	Unit	
V_{FM}	Forward Voltage	$I_F = 75\text{A}$	$T_J = 25^\circ\text{C}$	1.50		V	
			$T_J = 125^\circ\text{C}$	1.50			
t_{rr}	Reverse Recovery Time	$I_F = 75\text{A},$ $di/dt = 670\text{A}/\mu\text{s},$ $V_{rr} = 300\text{V},$ $V_{GE} = -15\text{V}$	$T_J = 25^\circ\text{C}$	112		ns	
			$T_J = 125^\circ\text{C}$	145			
I_{rr}	Peak Reverse Recovery Current		$T_J = 25^\circ\text{C}$	30		A	
			$T_J = 125^\circ\text{C}$	40			
Q_{rr}	Reverse Recovery Charge		$T_J = 25^\circ\text{C}$	2.05		μC	
			$T_J = 125^\circ\text{C}$	3.50			
E_{rec}	Reverse Recovery Energy		$T_J = 25^\circ\text{C}$	0.20		mJ	
			$T_J = 125^\circ\text{C}$	0.58			
$R_{\theta JC}$	Diode Thermal Resistance: Junction-To-Case (Per Leg)			0.537		$^\circ\text{C}/\text{W}$	

IGBT, Brake-Chopper

Maximum Rated Values($T_C=25^\circ\text{C}$ unless otherwise specified)

V_{CES}	Collector-Emitter Blocking Voltage		600	V
V_{GES}	Gate-Emitter Voltage		± 20	V
I_C	Continuous Collector Current	$T_C = 100^\circ\text{C},$	35	A
		$T_C = 25^\circ\text{C}$	69	A
I_{CM}	Peak Collector Current Repetitive	$T_J = 175^\circ\text{C}$	70	A
t_{SC}	Short Circuit Withstand Time		> 5	μs
P_D	Maximum Power Dissipation (IGBT)	$T_C = 25^\circ\text{C}$ $T_{Jmax}=175^\circ\text{C}$	220	W

Electrical Characteristics of IGBT($T_C=25^{\circ}\text{C}$ unless otherwise specified)

Static characteristics

Symbol	Description	Conditions	Min	Typ	Max	Unit
$V_{GE(th)}$	Gate-Emitter Threshold Voltage	$I_C = 1 \text{ mA}, V_{CE} = V_{GE}$	3.5	5.0	6.0	V
$V_{CE(sat)}$	Collector-Emitter Saturation Voltage	$I_C = 35\text{A}, V_{GE} = 15\text{V}$	$T_J = 25^{\circ}\text{C}$	1.60	1.90	V
			$T_J = 125^{\circ}\text{C}$	1.85		V
I_{CES}	Collector-Emitter Leakage Current	$V_{GE} = 0\text{V}, V_{CE} = V_{CES}, T_J = 25^{\circ}\text{C}$			1	mA
I_{GES}	Gate-Emitter Leakage Current	$V_{GE} = \pm 20\text{V}, V_{CE} = 0\text{V}, T_J = 25^{\circ}\text{C}$			200	nA
C_{ies}	Input Capacitance	$V_{CE} = 25\text{V}, V_{GE} = 0\text{V}, f = 1\text{MHz}$		2.11		nF
C_{oes}	Output Capacitance			0.20		nF
C_{res}	Reverse Transfer Capacitance			0.06		nF

Switching Characteristics

$t_{d(on)}$	Turn-on Delay Time	$V_{CC} = 300\text{V}, I_C = 35\text{A}, R_G = 30\Omega, V_{GE} = \pm 15\text{V},$ Inductive Load	$T_J = 25^{\circ}\text{C}$	130		ns
			$T_J = 125^{\circ}\text{C}$	120		
t_r	Rise Time		$T_J = 25^{\circ}\text{C}$	60		ns
			$T_J = 125^{\circ}\text{C}$	65		
$t_{d(off)}$	Turn-off Delay Time		$T_J = 25^{\circ}\text{C}$	120		ns
			$T_J = 125^{\circ}\text{C}$	125		
t_f	Fall Time		$T_J = 25^{\circ}\text{C}$	90		ns
			$T_J = 125^{\circ}\text{C}$	100		
E_{on}	Turn-on Switching Loss		$T_J = 25^{\circ}\text{C}$	0.42		mJ
			$T_J = 125^{\circ}\text{C}$	0.51		
E_{off}	Turn-off Switching Loss	$T_J = 25^{\circ}\text{C}$	0.31		mJ	
		$T_J = 125^{\circ}\text{C}$	0.54			
Q_g	Total Gate Charge	$T_J = 25^{\circ}\text{C}$	80		nC	
RBSOA	RBSOA	$I_C=70\text{A}, V_{CC}=480\text{V}, V_p=600\text{V}, R_g = 30\Omega, V_{GE}=\pm 15\text{V to } 0\text{V}, T_J = 150^{\circ}\text{C}$	Trapezoid			
SCSOA	SCSOA	$V_{CC} = 300\text{V}, V_{GE} = 15\text{V}, T_J = 150^{\circ}\text{C}$	5		μs	
$R_{\theta JC}$	IGBT Thermal Resistance: Junction-To-Case(Per Leg)			0.678	$^{\circ}\text{C/W}$	

Diode, Brake-Chopper

Maximum Rated Values($T_C=25^\circ\text{C}$ unless otherwise specified)

V_{RRM}	Repetitive Peak Reverse Voltage	600	V
I_F	Diode Continuous Forward Current	15	A
I_{FM}	Peak FWD Current Repetitive	30	A

Electrical Characteristics of FWD($T_C=25^\circ\text{C}$ unless otherwise specified)

Symbol	Description	Conditions	Min	Typ	Max	Unit
V_{FM}	Forward Voltage	$I_F = 15\text{A}$	$T_J = 25^\circ\text{C}$	1.20		V
			$T_J = 125^\circ\text{C}$	1.15		
I_{rr}	Peak Reverse Recovery Current	$I_F = 15\text{A},$ $di/dt = 550\text{A}/\mu\text{s},$ $V_{rr} = 300\text{V},$ $V_{GE} = -15\text{V}$	$T_J = 25^\circ\text{C}$	15		A
			$T_J = 125^\circ\text{C}$	30		
Q_{rr}	Reverse Recovery Charge	$I_F = 15\text{A},$ $di/dt = 550\text{A}/\mu\text{s},$ $V_{rr} = 300\text{V},$ $V_{GE} = -15\text{V}$	$T_J = 25^\circ\text{C}$	1.50		μC
			$T_J = 125^\circ\text{C}$	2.20		
E_{rec}	Reverse Recovery Energy	$I_F = 15\text{A},$ $di/dt = 550\text{A}/\mu\text{s},$ $V_{rr} = 300\text{V},$ $V_{GE} = -15\text{V}$	$T_J = 25^\circ\text{C}$	0.10		mJ
			$T_J = 125^\circ\text{C}$	0.18		
$R_{\theta JC}$	Diode Thermal Resistance: Junction-To-Case (Per Leg)			1.56		$^\circ\text{C}/\text{W}$

Internal NTC-Thermistor Characteristics

R_{25}	$T_C = 25^\circ\text{C}$	5		k Ω
$\Delta R/R$	$T_C = 100^\circ\text{C}, R_{100} = 481\Omega$		± 5	%
P_{25}	$T_C = 25^\circ\text{C}$	50		mW
$B_{25/50}$	$R_2 = R_{25} \exp[B_{25/50}(1/T_2 - 1/(298.15\text{K}))]$	3380		K
$B_{25/80}$	$R_2 = R_{25} \exp[B_{25/80}(1/T_2 - 1/(298.15\text{K}))]$	3440		K

Module

Symbol	Description	Min	Typ	Max	Unit
V _{iso}	Isolation Voltage (All Terminals Shorted) f = 50Hz, 1minute	2500			V
T _J	Maximum Junction Temperature			150	°C
T _{JOP}	Maximum Operating Junction Temperature Range	-40		+150	°C
T _{stg}	Storage Temperature	-40		+125	°C
CTI	Comparative Tracking Index	200			V
R _{θCS}	Case-To-Sink Thermally (Conductive Grease Applied)		0.1		°C/W
M	Mounting Screw:M3	1.5		2.0	N·m
G	Weight		30		g

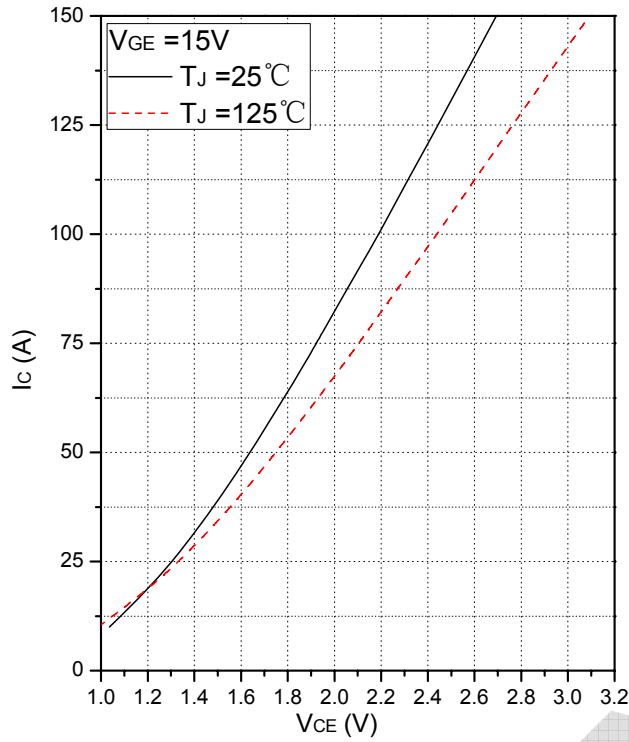

Fig.1 Typical Saturation Voltage Characteristics (Inverter)

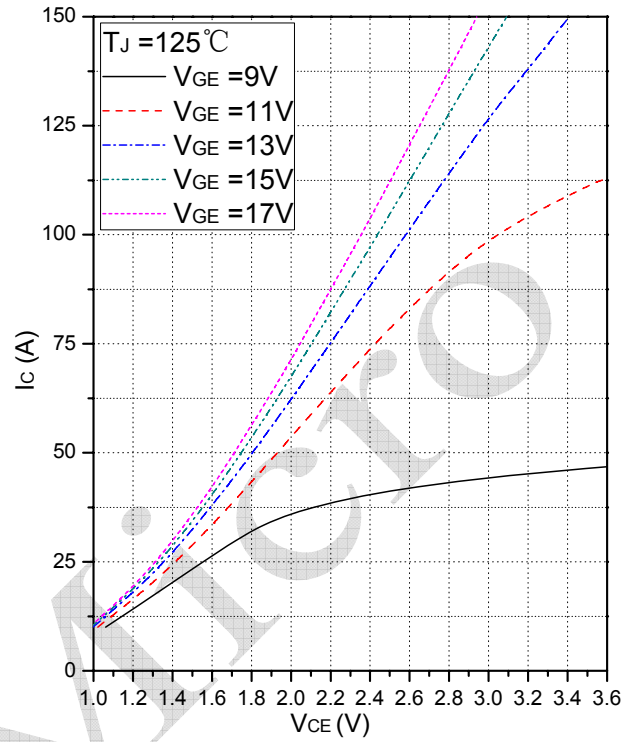

Fig.2 Typical Output Characteristics (Inverter)

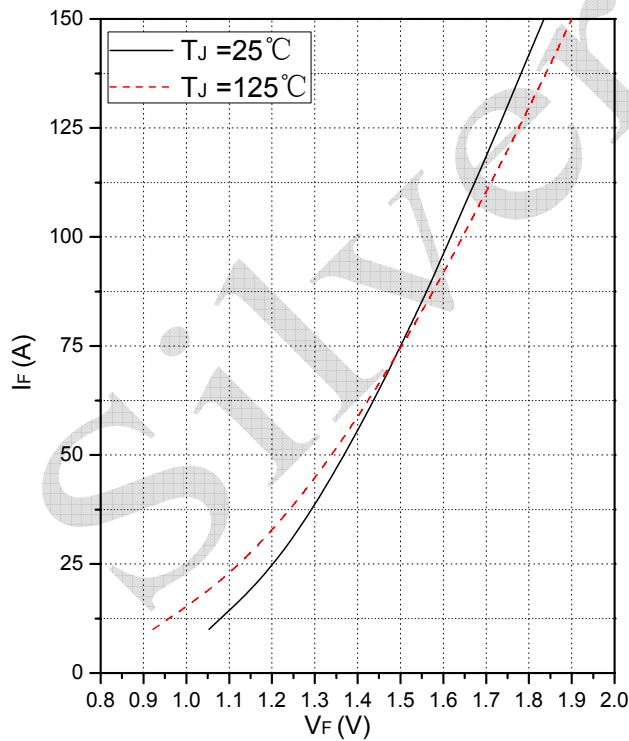

Fig.3 Forward Characteristics of FWD (Inverter)

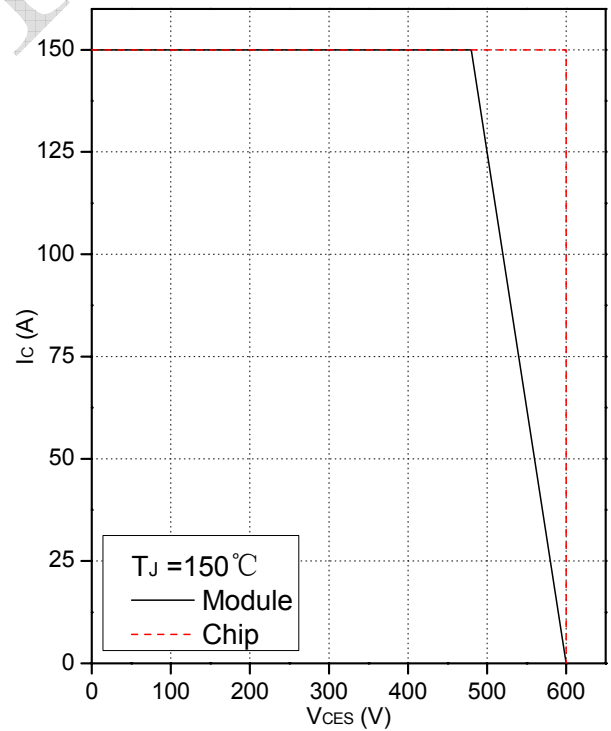

Fig.4 Reverse Bias Safe Operation Area (RBSOA)

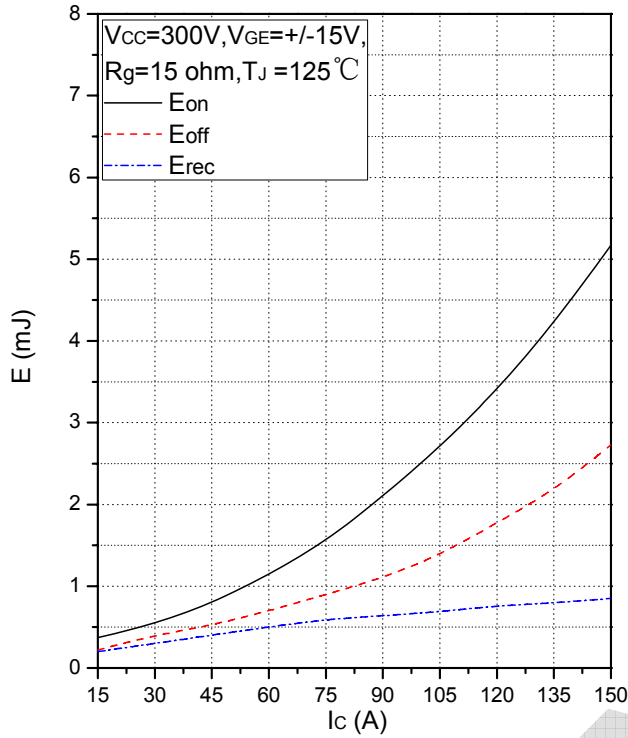

Fig.5 Typical Switching Loss vs. Collector Current (Inverter)

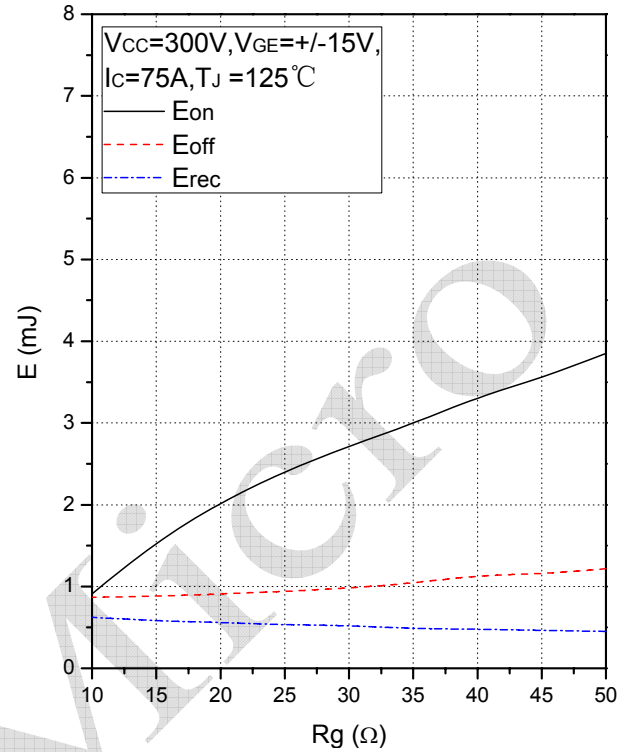

Fig.6 Typical Switching Loss vs. Gate Resistance (Inverter)

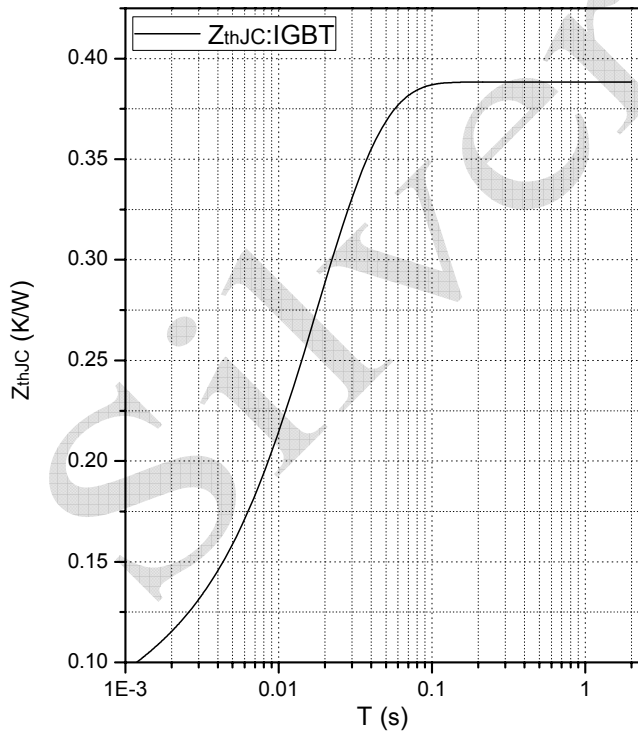

Fig.7 Transient Thermal Impedance IGBT (Inverter)

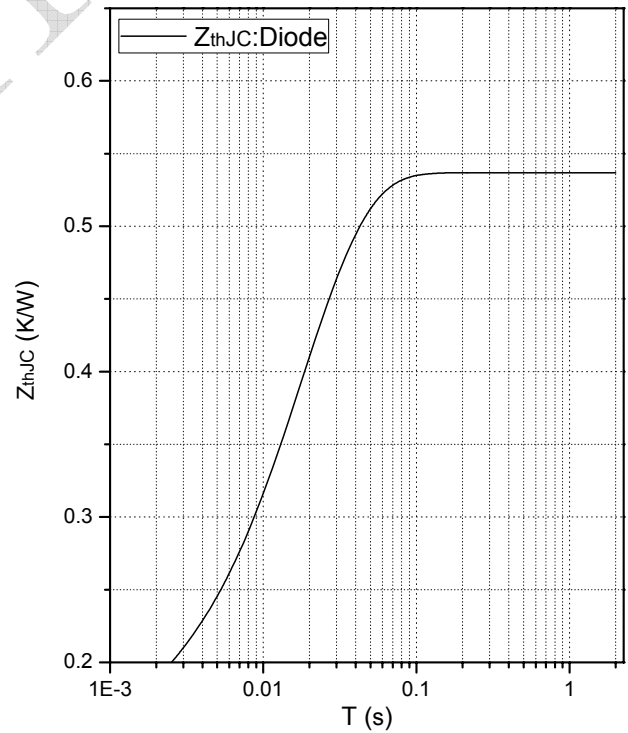

Fig.8 Transient Thermal Impedance Diode(Inverter)

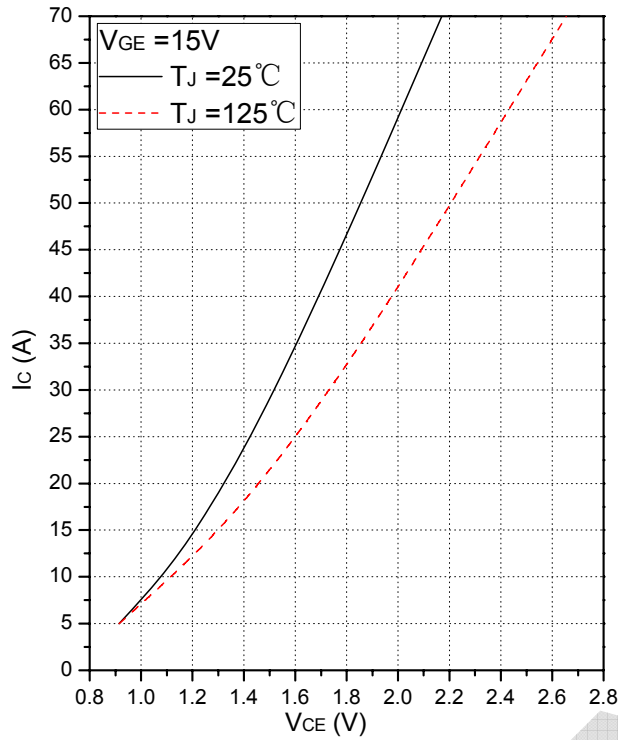

Fig.9 Typical Saturation Voltage Characteristics(Chopper)

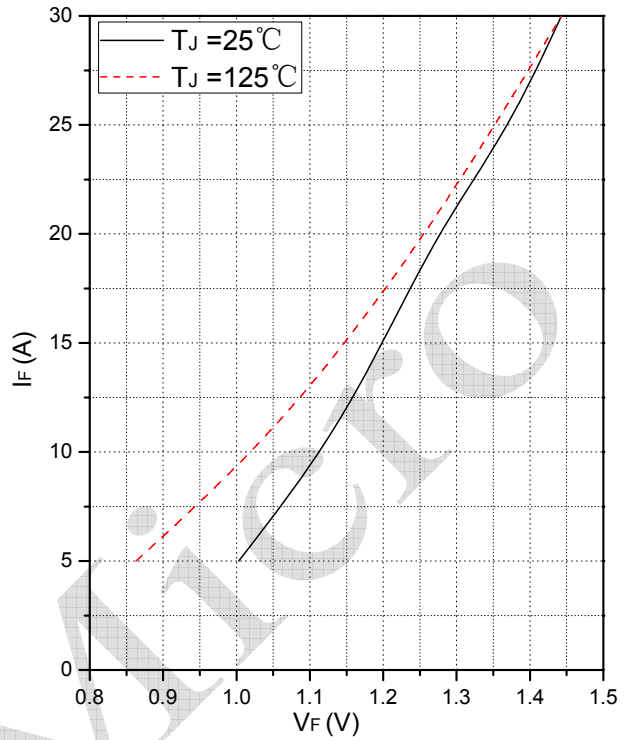

Fig.10 Forward Characteristics of FWD (Chopper)

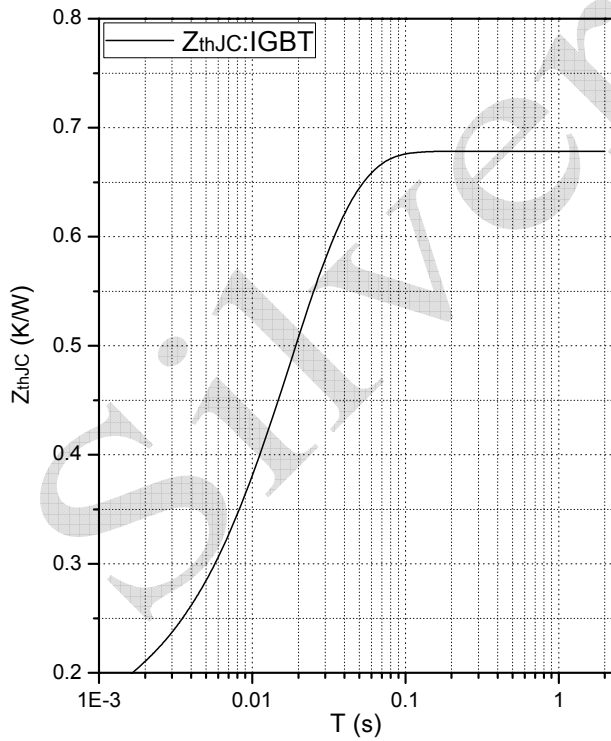

Fig.11 Transient Thermal Impedance IGBT (Chopper)

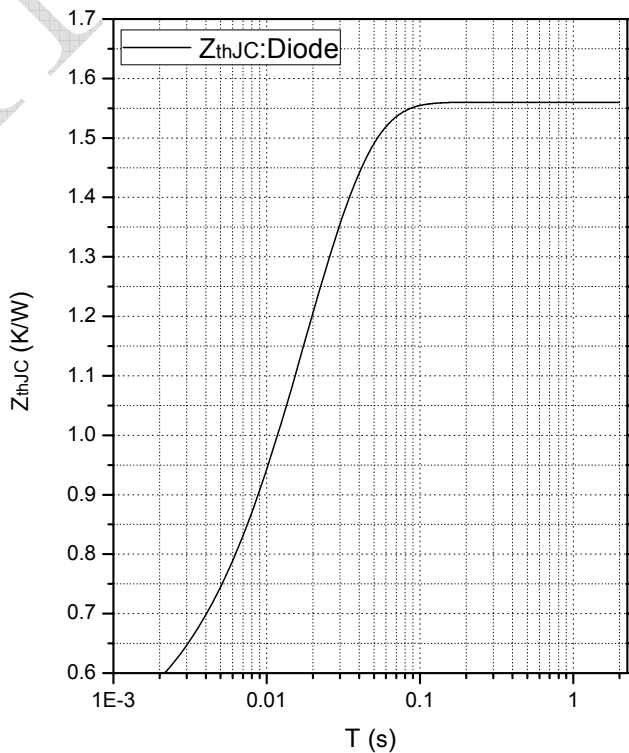

Fig.12 Transient Thermal Impedance Diode(Chopper)

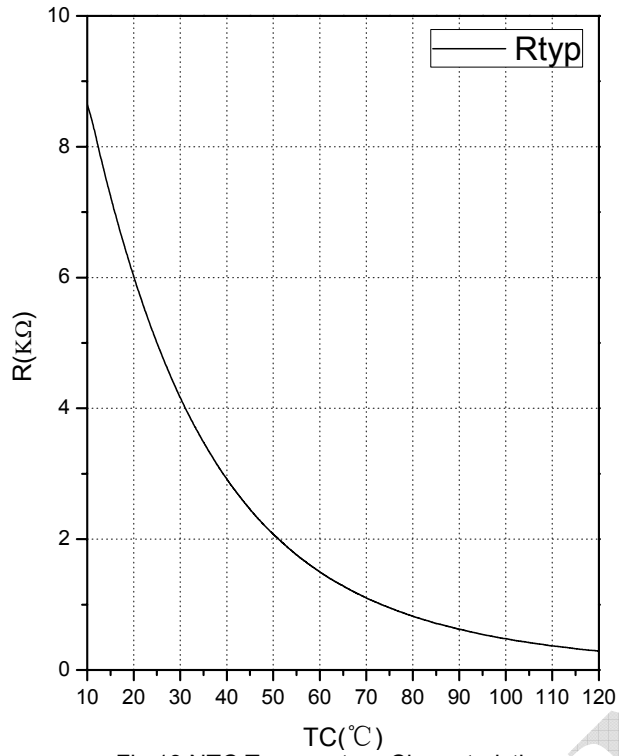

Fig.13 NTC Temperature Characteristics

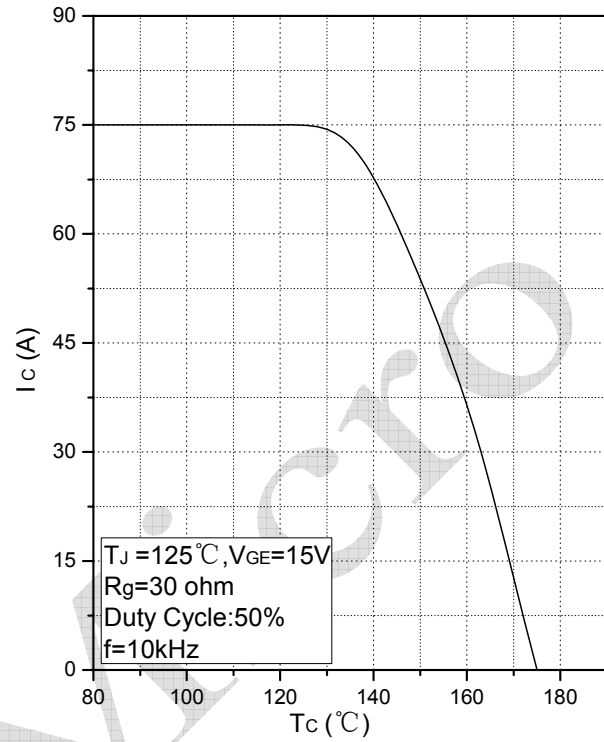
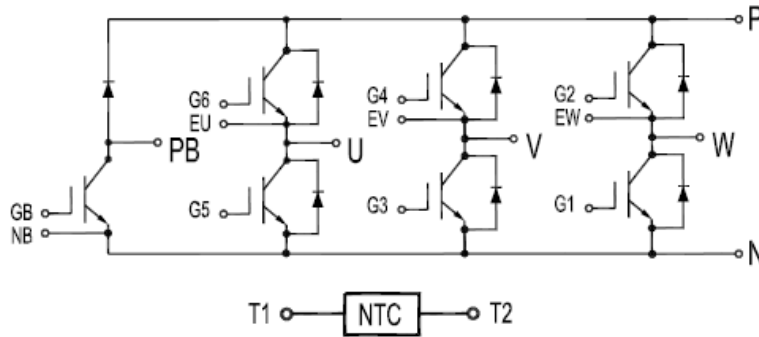
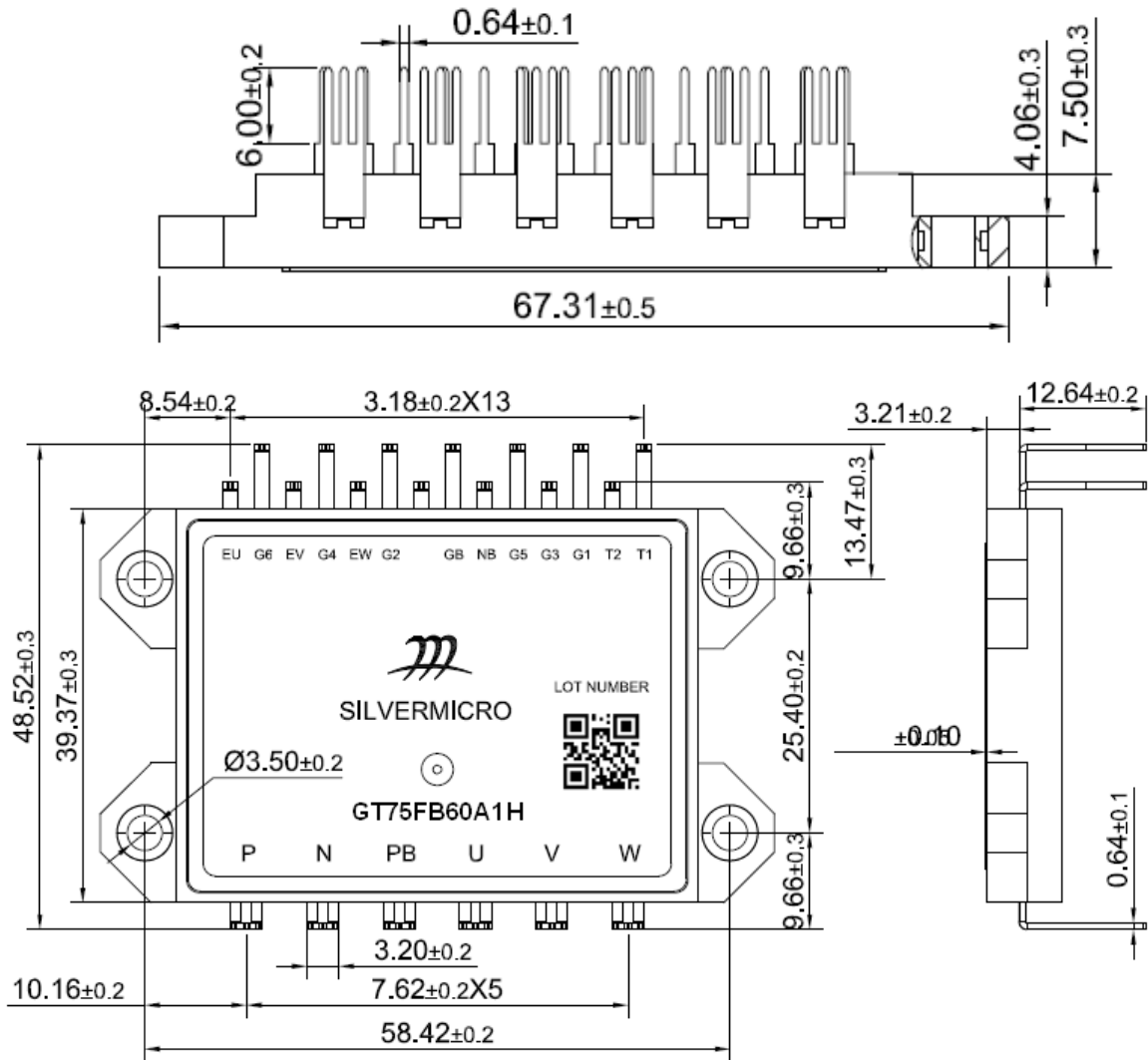

Fig.14 Rated Current vs. Temperature

Internal Circuit:



Package Outline (Unit: mm):



Announcement

Information in this document is believed to be accurate and reliable. However, NJSME does not give any representations or warranties, expressed or implied, as to the accuracy or completeness of such information and shall have no liability for the consequences of use of such information.

Right to Make Changes

NJSME reserves the right to make changes to information published in this document, including without limitation specifications and product descriptions, at any time and without notice. This document supersedes and replaces all information supplied prior to the publication hereof.

SilverMicro