

GTM150TL65B9H

IGBT Module

Features:

- Field Stop Trench Gate IGBT
- Short Circuit Rated > 10 μ s
- Low Saturation Voltage
- Low Switching Loss
- 100% RBSOA Tested (2 \times I_c)
- Low Stray Inductance
- Lead Free, Compliant with RoHS Requirement

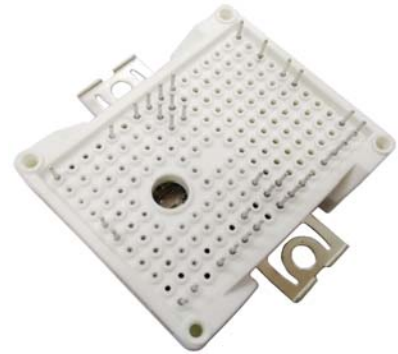

Application:

- 3-Level-Applications

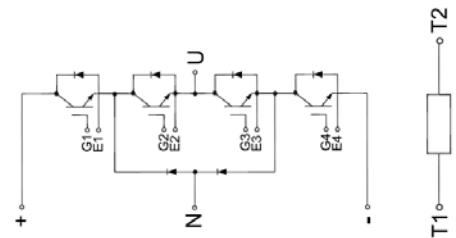

IGBT, Inverter

Maximum Rated Values (T_C=25°C unless otherwise specified)

V _{CES}	Collector-Emitter Blocking Voltage		650	V
V _{GES}	Gate-Emitter Voltage		±20	V
I _C	Continuous Collector Current	T _C =100°C	150	A
		T _C =25°C	260	A
I _{CM}	Repetitive Peak Collector Current	T _J =175°C	300	A
t _{sc}	Short Circuit Withstand Time		>10	μs
P _D	Maximum Power Dissipation per IGBT	T _C =25°C	806	W
		T _{Jmax} =175°C		

Electrical Characteristics of IGBT ($T_C=25^{\circ}\text{C}$ unless otherwise specified)

Static Characteristics

Symbol	Description	Conditions	Min	Typ	Max	Unit
$V_{GE(th)}$	Gate-Emitter Threshold Voltage	$I_C=1\text{mA}$, $V_{CE}=V_{GE}$	5.0	6.1	6.8	V
$V_{CE(sat)}$	Collector-Emitter Saturation Voltage	$I_C=150\text{A}$, $V_{GE}=15\text{V}$	$T_J=25^{\circ}\text{C}$	1.55		V
			$T_J=125^{\circ}\text{C}$	1.70		V
			$T_J=150^{\circ}\text{C}$	1.70		V
I_{CES}	Collector-Emitter Leakage Current	$V_{GE}=0\text{V}$, $V_{CE}=V_{CES}$, $T_J=25^{\circ}\text{C}$			1	mA
I_{GES}	Gate-Emitter Leakage Current	$V_{GE}=0\text{V}$, $V_{CE}=V_{CES}$, $T_J=25^{\circ}\text{C}$			200	nA
C_{ies}	Input Capacitance	$V_{CE}=25\text{V}$, $V_{GE}=0\text{V}$, $f=1\text{MHz}$		12.17		nF
C_{oes}	Output Capacitance			0.56		nF
C_{res}	Reveres Transfer Capacitance			0.40		nF

Switching Characteristics

$t_{d(on)}$	Turn-on Delay Time	$V_{CC}=300\text{V}$, $I_C=150\text{A}$, $R_{Gon}=4.7\Omega$, $V_{GE}=\pm 15\text{V}$, Inductive Load	$T_J=25^{\circ}\text{C}$	0.21		μs
			$T_J=125^{\circ}\text{C}$	0.21		
			$T_J=150^{\circ}\text{C}$	0.21		
t_r	Rise Time		$T_J=25^{\circ}\text{C}$	0.10		μs
			$T_J=125^{\circ}\text{C}$	0.10		
			$T_J=150^{\circ}\text{C}$	0.10		
$t_{d(off)}$	Turn-off Delay Time		$T_J=25^{\circ}\text{C}$	0.22		μs
			$T_J=125^{\circ}\text{C}$	0.22		
			$T_J=150^{\circ}\text{C}$	0.22		
t_f	Fall Time	$T_J=25^{\circ}\text{C}$	0.11		μs	
		$T_J=125^{\circ}\text{C}$	0.14			
		$T_J=150^{\circ}\text{C}$	0.15			
E_{on}	Turn-on Switching Loss	$V_{CC}=300\text{V}$, $I_C=150\text{A}$, $R_{Gon}=4.7\Omega$, $V_{GE}=\pm 15\text{V}$, $di/dt=1200\text{A}/\mu\text{s}$ ($T_J=150^{\circ}\text{C}$) Inductive Load	$T_J=25^{\circ}\text{C}$	1.22		mJ
		$T_J=125^{\circ}\text{C}$	1.64			
		$T_J=150^{\circ}\text{C}$	1.67			

E _{off}	Turn-off Switching Loss	V _{CC} =300V, I _C =150A, R _{Goff} =4.7Ω, V _{GE} =±15V, dv/dt=3600V/μs(T _J =150°C) Inductive Load	T _J =25°C	2.95	mJ
			T _J =125°C	4.35	
			T _J =150°C	4.65	
Q _g	Total Gate Charge	V _{GE} =+15V...-15V	T _J =25°C	0.89	μC
RBSOA	I _C =300A, V _{CC} =600V, V _p =650V, R _{Goff} = 4.7Ω, V _{GE} =+15V to 0V, T _J =150°C			Trapezoid	
SC Data	V _{CC} =300V, t _p =10μs, V _{GE} =+/-15V, R _{Gon} =10ohm, R _{Goff} =10ohm, T _J =25°C			1012	A
R _{θJC}	IGBT Thermal Resistance: Junction-To-Case			0.186	°C/W

Diode, Reverse

Maximum Rated Values (T_C=25°C unless otherwise specified)

V _{RRM}	Repetitive Peak Reverse Voltage	650	V
I _F	Diode Continuous Forward Current	150	A
I _{FM}	Diode Maximum Forward Current	300	A

Electrical Characteristics of FWD (T_C=25°C unless otherwise specified)

Symbol	Description	Conditions	Min	Typ	Max	Unit
V _{FM}	Forward Voltage	I _C =150A	T _J =25°C	1.60		V
			T _J =125°C	1.70		
			T _J =150°C	1.70		
t _{rr}	Reverse Recovery Time		T _J =25°C	0.10		μs
			T _J =125°C	0.15		
			T _J =150°C	0.16		
I _{rr}	Peak Reverse Recovery Current	I _F =150A, -di _F /dt=1200A/μs(T _J =150°C), V _R =300V, V _{GE} =-15V	T _J =25°C	65.6		A
			T _J =125°C	78.1		
			T _J =150°C	82.8		
Q _{rr}	Reverse Recovery Charge		T _J =25°C	4.07		μC
			T _J =125°C	7.48		
			T _J =150°C	8.77		

E _{rec}	Reverse Recovery Energy	I _F =150A, -di _F /dt=500A/μs(T _J =150°C), V _R =300V, V _{GE} =-15V	T _J =25°C	0.30	mJ
			T _J =125°C	1.42	
			T _J =150°C	1.72	
R _{θJC}	Diode Thermal Resistance: Junction-To-Case			0.308	°C/W

Diode, 3-Level Maximum Rated Values (T_C=25°C unless otherwise specified)

V _{RRM}	Repetitive Peak Reverse Voltage	650	V
I _F	Diode Continuous Forward Current	150	A
I _{FM}	Diode Maximum Forward Current	300	A

Electrical Characteristics of FWD (T_C=25°C unless otherwise specified)

Symbol	Description	Conditions	Min	Typ	Max	Unit
V _{FM}	Forward Voltage	I _C =150A	T _J =25°C	1.60		V
			T _J =125°C	1.70		
			T _J =150°C	1.70		
t _{rr}	Reverse Recovery Time	I _F =150A, -di _F /dt=1200A/μs(T _J =150°C), V _R =300V, V _{GE} =-15V	T _J =25°C	0.10		μs
			T _J =125°C	0.15		
			T _J =150°C	0.16		
I _{rr}	Peak Reverse Recovery Current	I _F =150A, -di _F /dt=1200A/μs(T _J =150°C), V _R =300V, V _{GE} =-15V	T _J =25°C	65.6		A
			T _J =125°C	78.1		
			T _J =150°C	82.8		
Q _{rr}	Reverse Recovery Charge	I _F =150A, -di _F /dt=1200A/μs(T _J =150°C), V _R =300V, V _{GE} =-15V	T _J =25°C	4.07		μC
			T _J =125°C	7.48		
			T _J =150°C	8.77		
E _{rec}	Reverse Recovery Energy	I _F =150A, -di _F /dt=1200A/μs(T _J =150°C), V _R =300V, V _{GE} =-15V	T _J =25°C	0.30		mJ
			T _J =125°C	1.42		
			T _J =150°C	1.72		
R _{θJC}	Diode Thermal Resistance: Junction-To-Case			0.308		°C/W

Internal NTC- Thermistor Characteristic

Symbol	Condition	Typ.	Max.	Units
R ₂₅	T _C =25°C	5		kΩ
ΔR/R	T _C =100°C, R ₁₀₀ =481Ω		±5	%
P ₂₅	T _C =25°C	50		mW
B _{25/50}	$R_2=R_{25} \exp[B_{25/50}(1/T_2-1/(298.15K))]$	3380		K
B _{25/80}	$R_2=R_{25} \exp[B_{25/80}(1/T_2-1/(298.15K))]$	3440		K

Module

Symbol	Description	Min	Typ	Max	Unit
V _{iso}	Isolation Voltage (All Terminals Shorted) f = 50Hz, 1minute	2500			V
T _J	Maximum Junction Temperature			175	°C
T _{JOP}	Maximum Operating Junction Temperature Range	-40		+150	°C
T _{stg}	Storage Temperature	-40		+125	°C
CTI	Comparative Tracking Index	200			V
R _{θCS}	Case-To-Sink Thermally (Conductive Grease Applied)		0.05		°C/W
T	Mounting Screw:M4	2.0		2.3	N·m
G	Weight		40		g

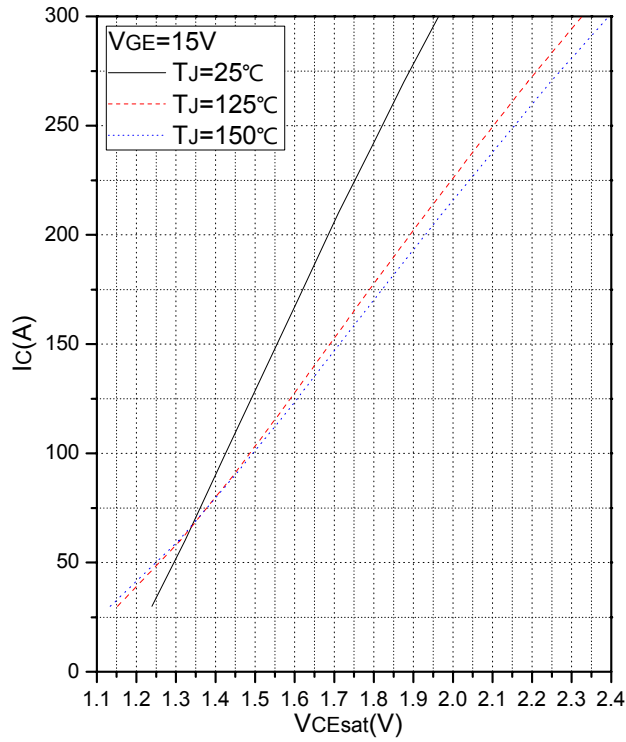

Fig.1 Typical Saturation Voltage Characteristics

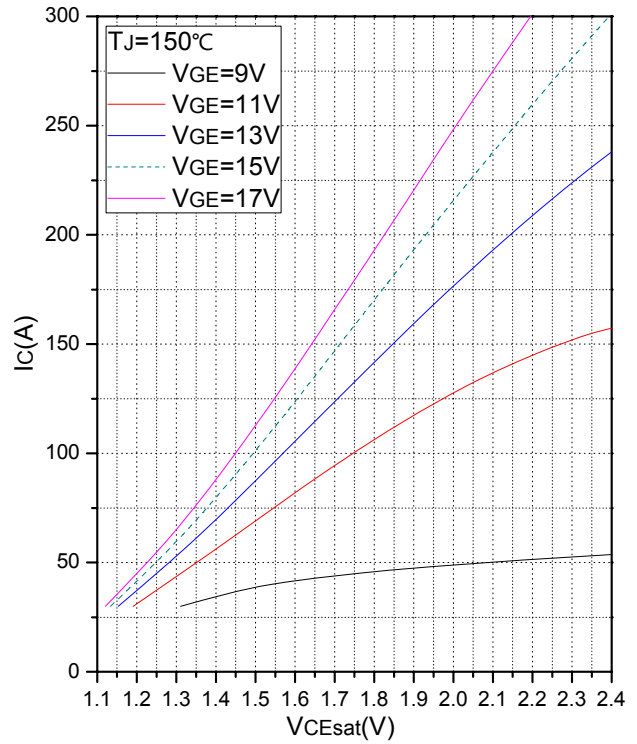

Fig.2 Typical Output Characteristics

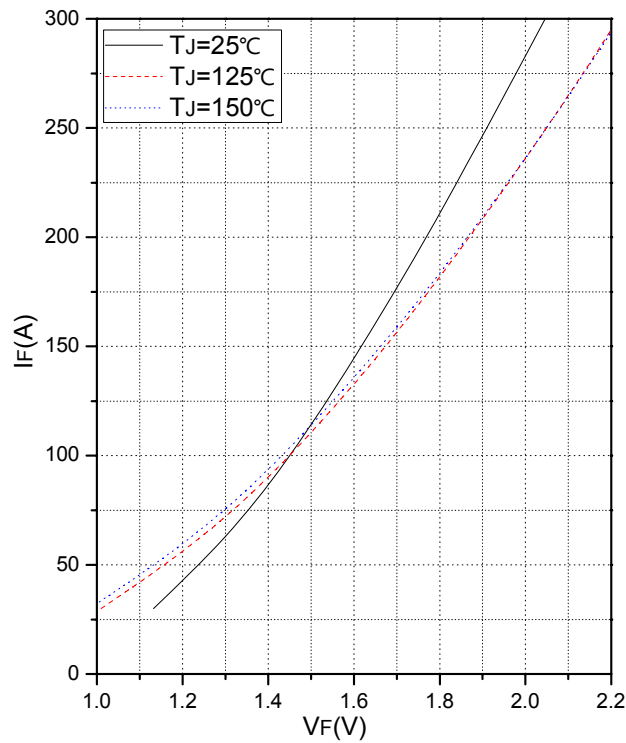

Fig.3 Forward Characteristics of Diode (Reverse)

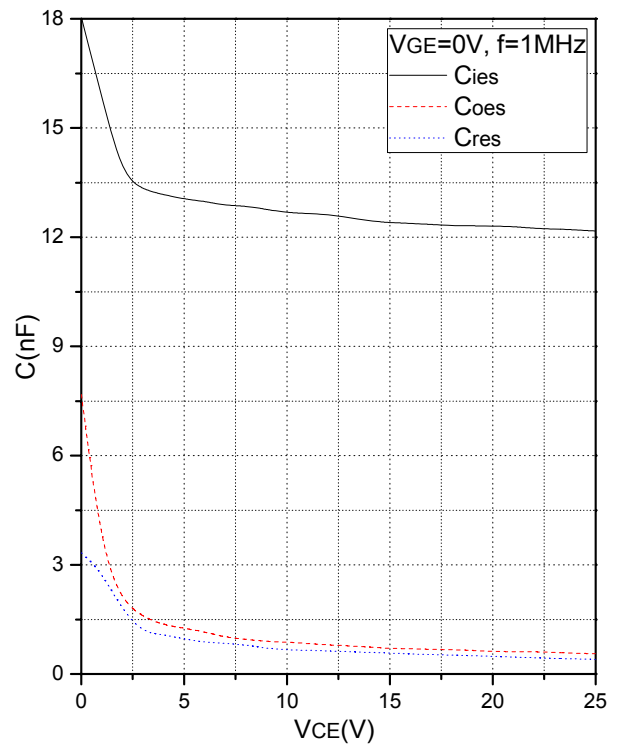

Fig.4 Capacitance Characteristics

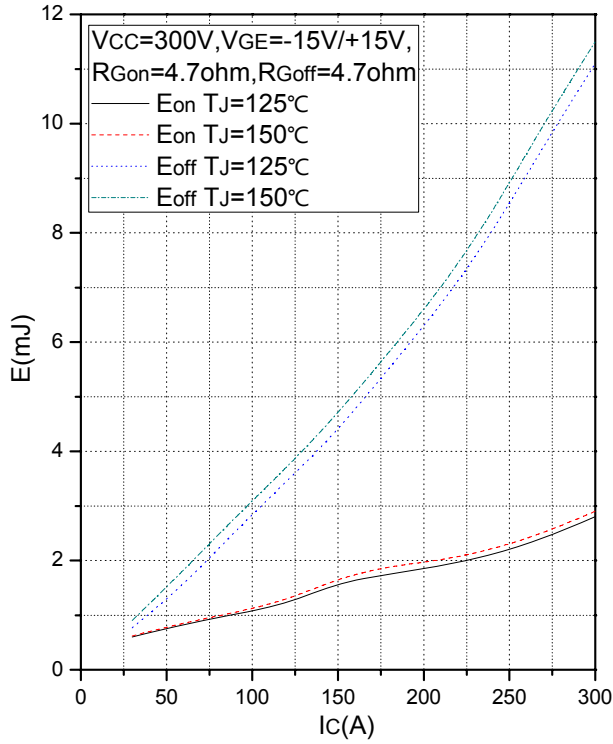

Fig.5 Typical Switching Loss vs. Collector Current

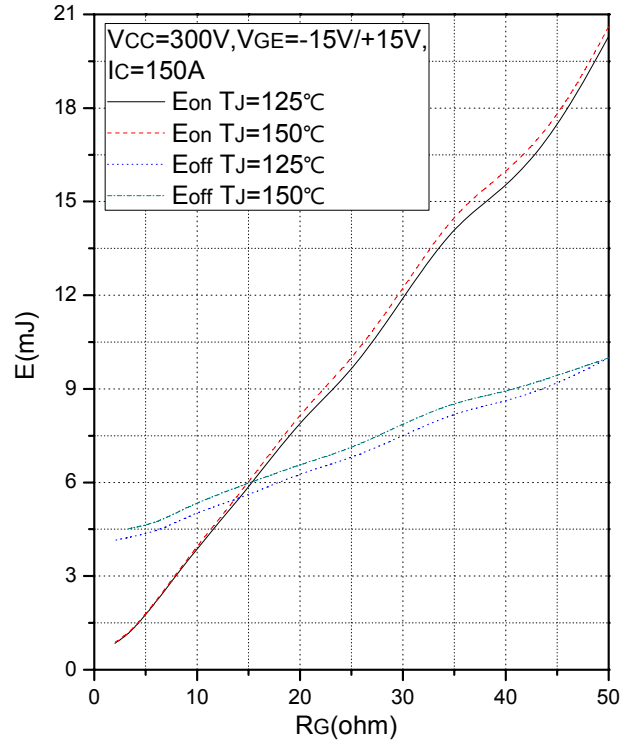

Fig.6 Typical Switching Loss vs. Gate Resistance

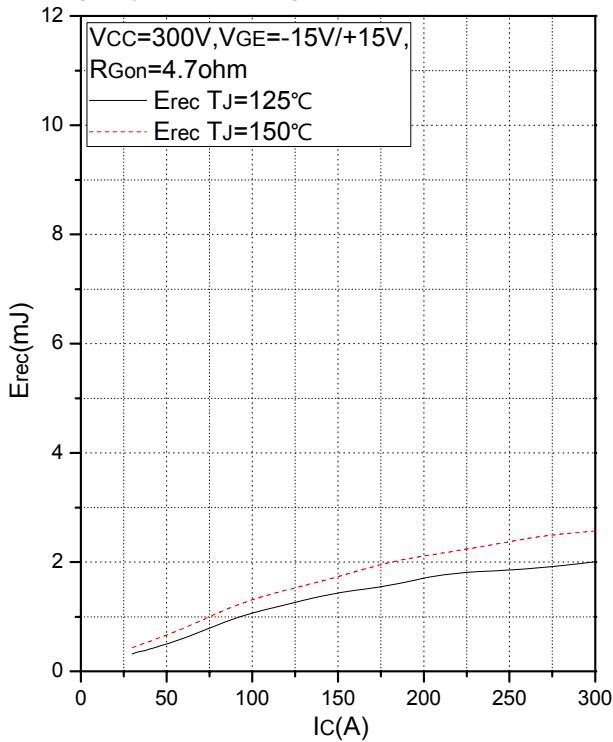

Fig.7 Typical Switching Loss vs. Collector Current

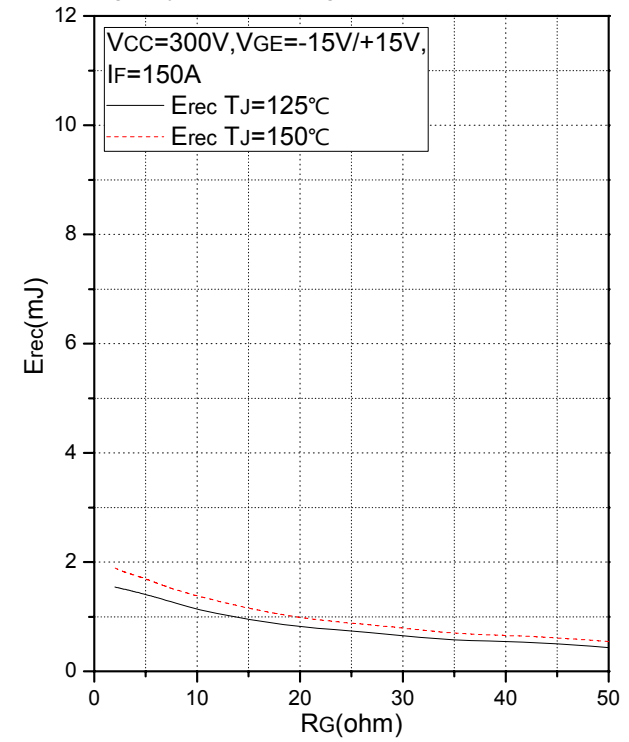

Fig.8 Typical Switching Loss vs. Gate Resistance

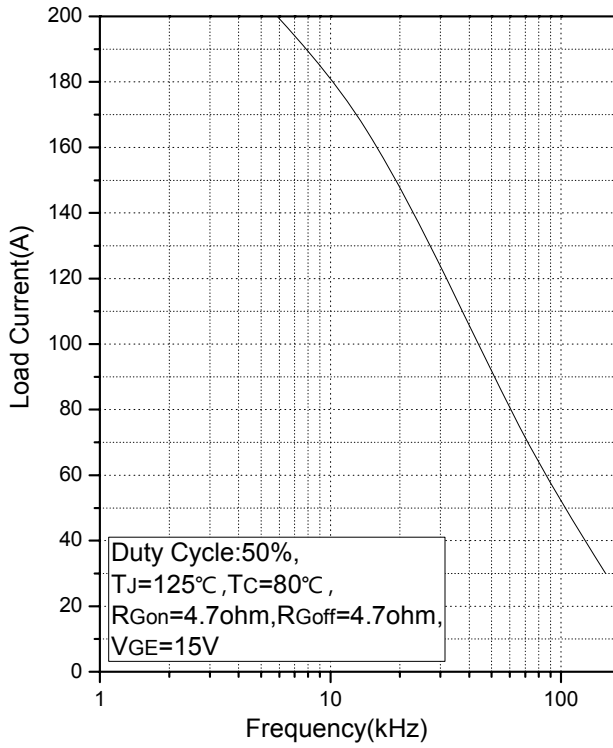

Fig.9 Typical Load Current vs. Frequency

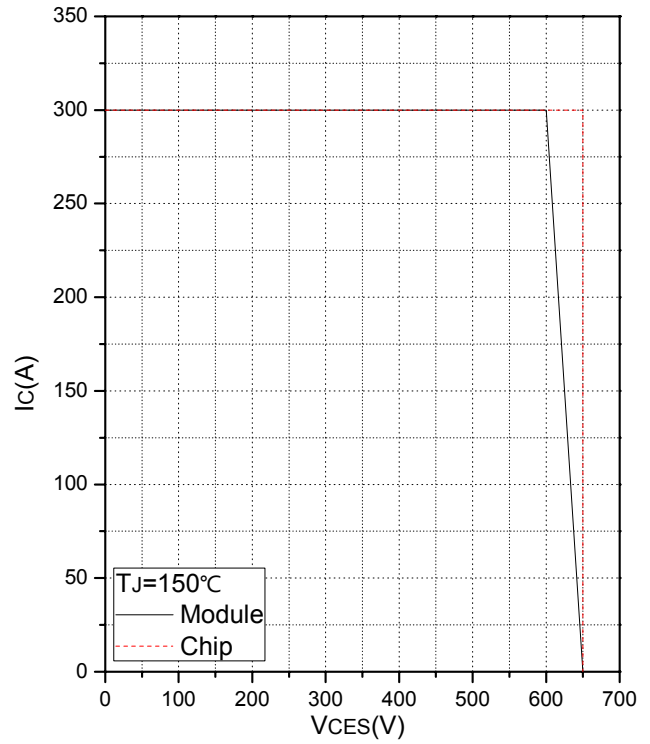

Fig.10 Reverse Bias Safe Operation Area (RBSOA)

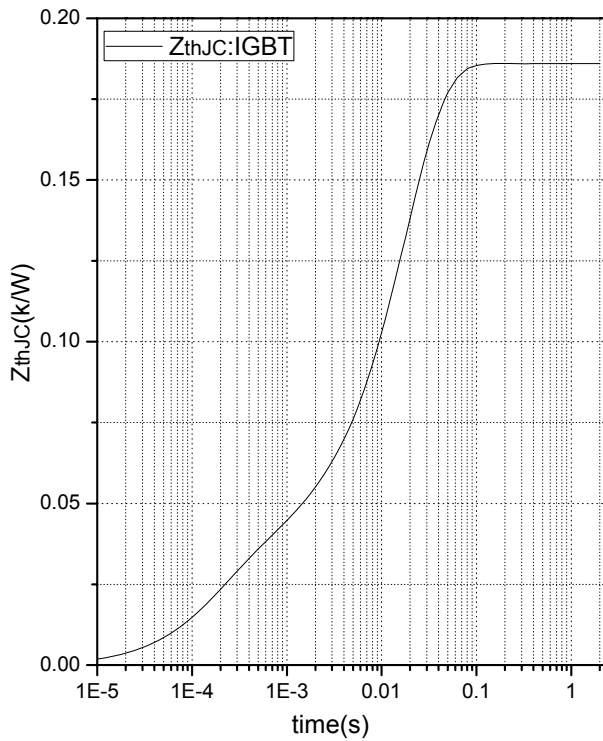

Fig.11 Transient Thermal Impedance (IGBT)

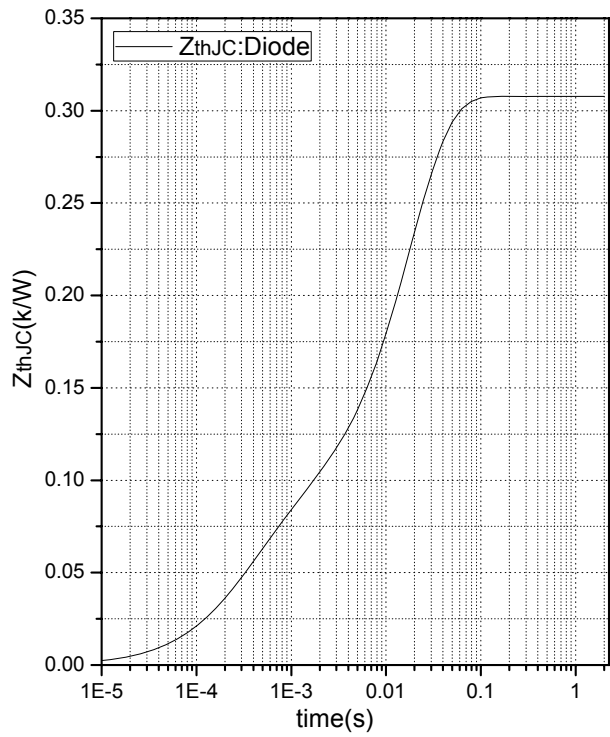

Fig.12 Transient Thermal Impedance (Diode)

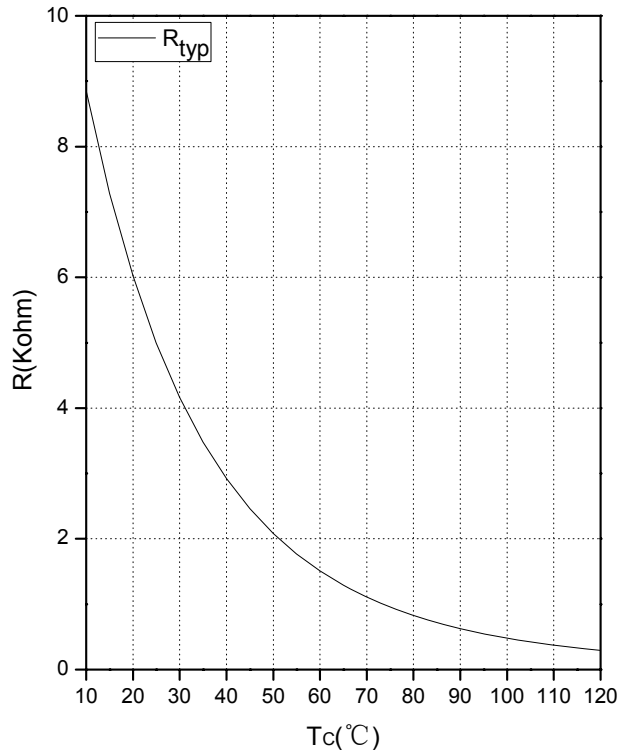

Fig.13 NTC Temperature Characteristics

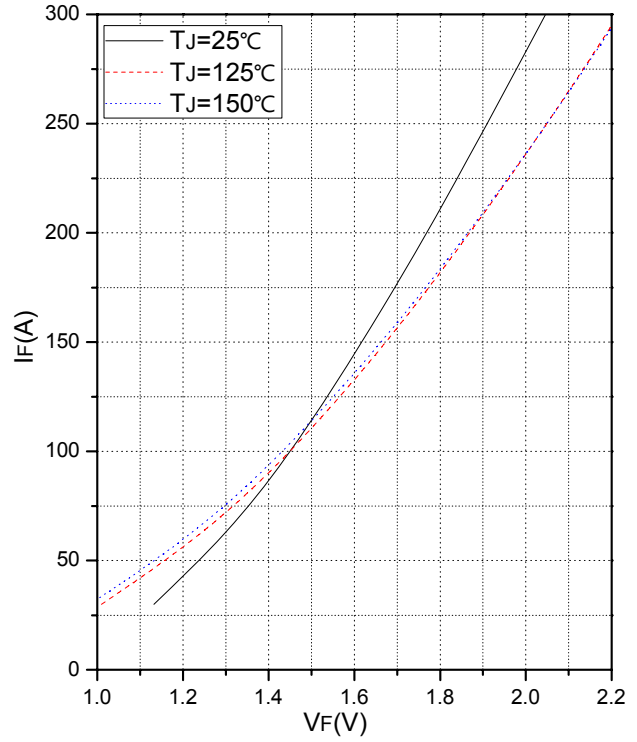

Fig.14 Forward Characteristics of Diode (3-Level)

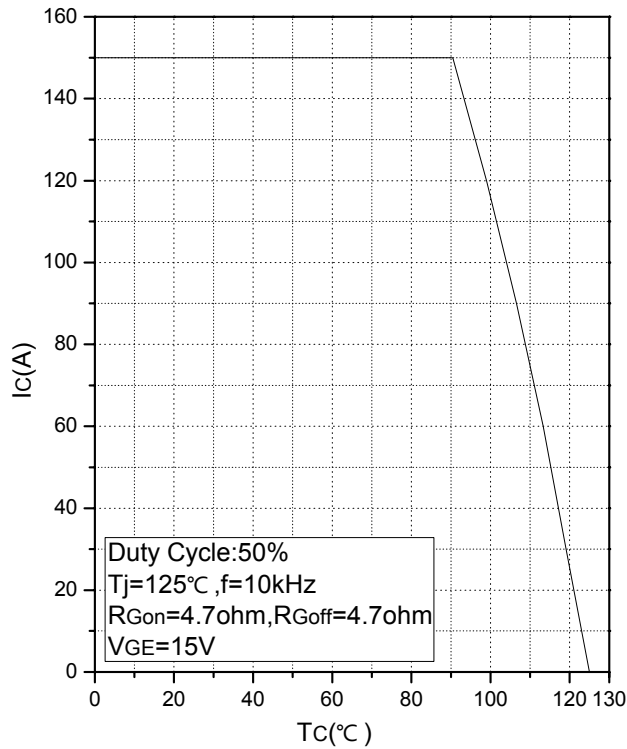
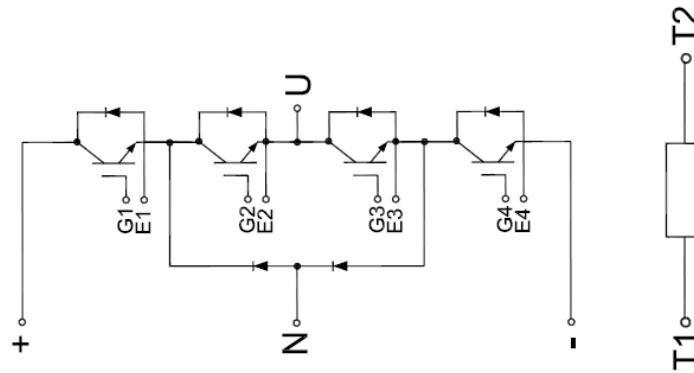
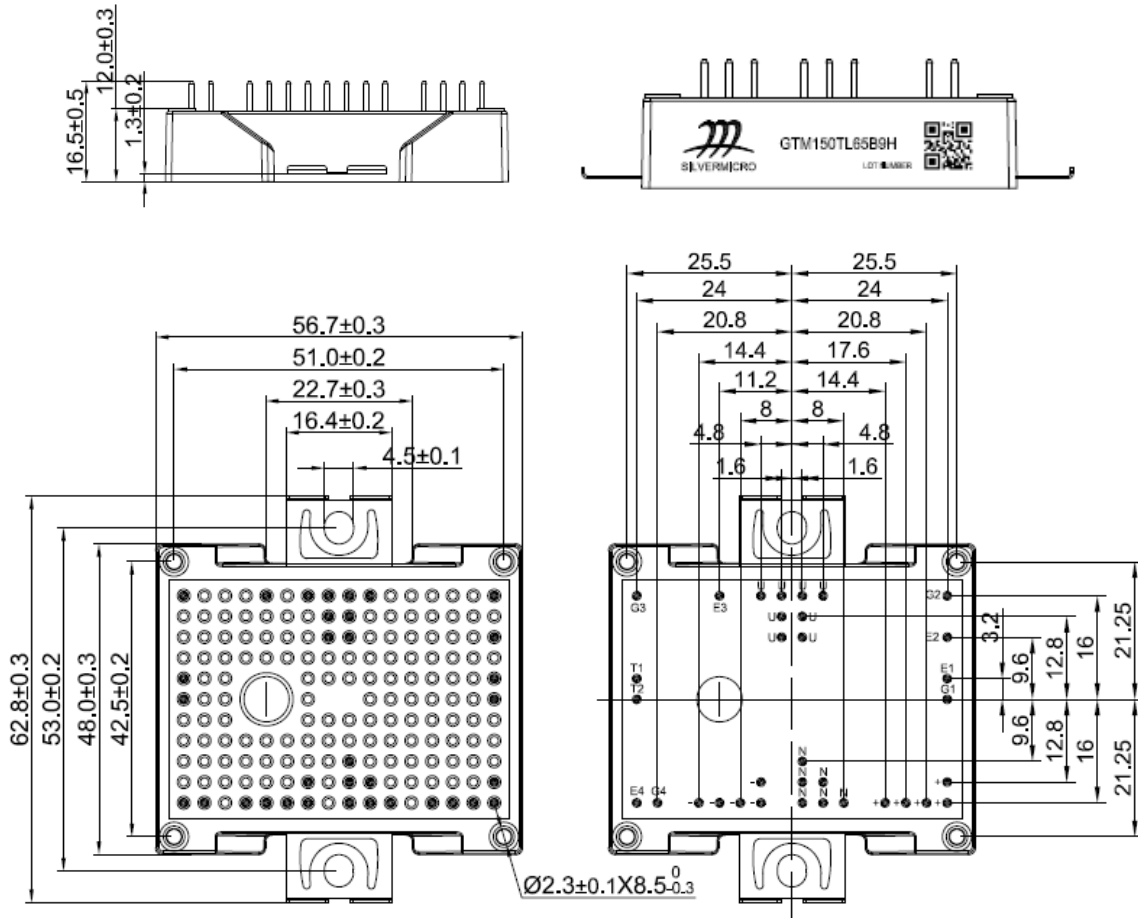

Fig.15 Rated Current vs. Temperature

Internal Circuit



Package Outline (Unit: mm):





Date	Revision	Notes
08/28/2018	01	Initial release
04/09/2019	02	Update outline
09/23/2019	03	Changed Mounting Torque

Announcement

Information in this document is believed to be accurate and reliable. However, NJSME does not give any representations or warranties, expressed or implied, as to the accuracy or completeness of such information and shall have no liability for the consequences of use of such information.

Right to Make Changes

NJSME reserves the right to make changes to information published in this document, including without limitation specifications and product descriptions, at any time and without notice. This document supersedes and replaces all information supplied prior to the publication hereof.